

AEROPRAKT INFORMATION BULLETIN

VIBRATIONS OF THE MAIN LANDING GEAR LEGS OF A-22LS AND A-22L2 AIRPLANES. IB A-22LS-01

MANDATORY

Repeating symbols:

Please, pay attention to the following symbols throughout this document marking important information.

- ▲ **WARNING:** Identifies an instruction, which if not followed may cause serious injury or even death.
- **CAUTION:** Denotes an instruction, which if not followed, may cause severe damage.
- ◆ **NOTE:** Information useful for better handling.

1) Planning information

1.1) Aircraft affected

All versions of Aeroprakt-22LS airplanes series No. 1-42 and Aeroprakt-22L2 airplanes series No. 345.

1.2) Reason

It was found out that an energetic braking on a hard surface runway causes resonance vibration of the main landing gear legs. The vibrations in their turn cause elastic oscillations of the bottom fuselage skin in the area of the outer lower attachment fitting of the main landing gear leg, which may result in fatigue cracks in the rear web of the transverse beam of the main landing gear attachment. To reduce the probability of crack creation it is necessary to increase the stiffness of fuselage skin in the area of the attachment fittings of the main landing gear using the reinforcing angles. **It is strongly recommended to avoid the resonance vibrations of the main landing gear.**

1.3) Subject

Rear web of the transverse beam of the main landing gear attachment.

1.4) Compliance

Inspect the rear web of the transverse beam of the main landing gear attachment in the area of the lower hole of the main LG attachment.

1.5) Approval

The technical content of this Information Bulletin has been approved by Aeroprakt

1.6) Manpower

Estimated man-hours:

Work according to p. 3.1.2 is performed within 2-3 hours.

1.7) Mass data

Weight change – none (insignificant +120 g).

1.8) Revision of other documents

None

1.9) Spare parts

The reinforcing angles are supplied by the local dealer.

2) Spare parts information

2.1) Spare parts cost

Cost of the new parts: angle (2 pcs.) – free of charge, if cost of delivery is paid by the customer.

2.2) Special tooling / materials

For inspection of the beam no tools are required.

For repair: set of wrenches, drill bits: Ø3.1 mm, Ø6.2 mm, reamers: Ø1/4H7, drill, Clico fasteners, riveting gun, primer.

3) Accomplishment / Instructions

3.1) Instructions

3.1.1) Inspection of the beam

1. Inspect the beam for cracks in the specified (see fig. 1).

If cracks are found it is necessary to perform the repair work according to p. 3.1.2, otherwise carry out inspection regularly.

◆ **NOTE:** The beam must be inspected on the sides of both left and right landing gear leg, regardless the fact that the figure below shows only the right leg.

3.1.2) Reinforcement and repair of fuselage

1. If cracks are found in the beam (see fig. 1) it is necessary to drill the crack ends with Ø3.1 mm drill bit, remove the burrs and coat with primer.
2. Remove the bolts (13) of fitting (2) attachment to fuselage (see fig. 2).
3. Drill out the rivets (11, 12) with Ø3.1 mm drill bit (see fig. 2).
4. Apply the reinforcing angle to fuselage (1), drill it to the fuselage and fix with Clico fasteners.
5. Drill the bolt holes (13) with Ø6.2 mm drill bit in fuselage and ream them with Ø1/4H7 reamer.
6. Remove the Clico fasteners and angle and clean it from metal chips.
7. Fix the angle (1) with Clico fasteners.
8. Install the bolts (13) with primer.
9. Install the rivets (11, 12).

4) Appendix:
The figures below contain additional information.

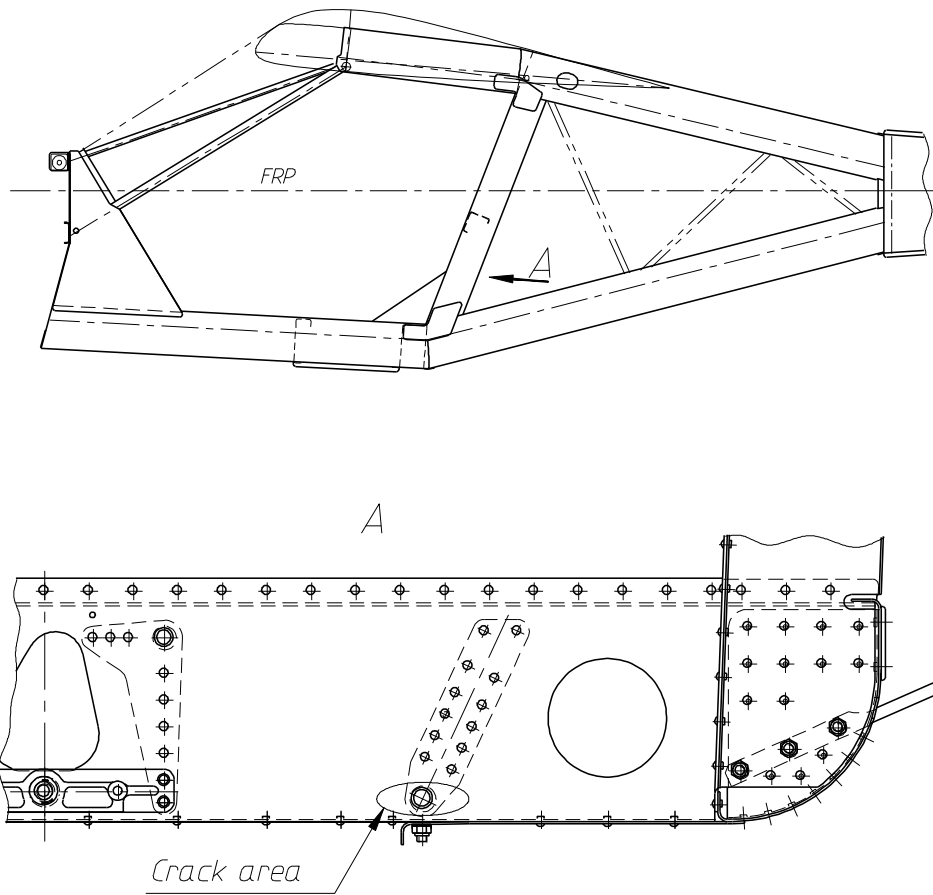
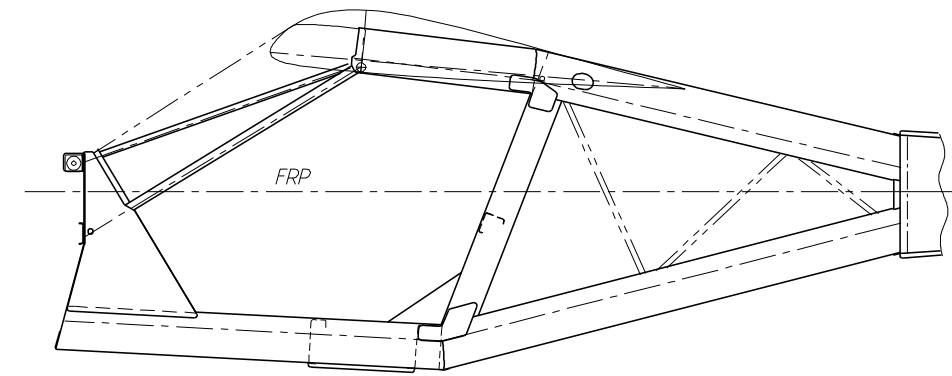

Fig. 1



1 - angle

11 - rivet 3-8-Ан.окс. ОСТ1 34078-80

12 - rivet 3-9-Ан.окс. ОСТ1 34078-80

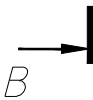
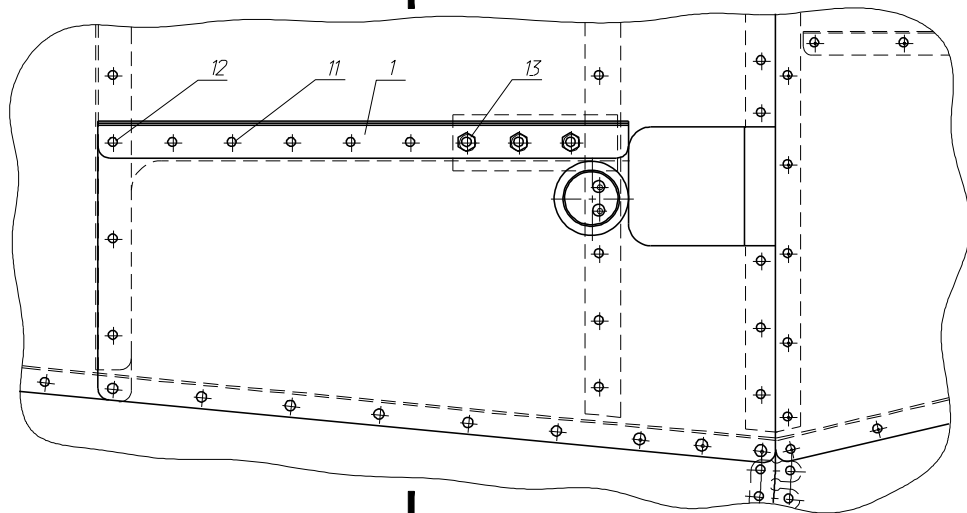
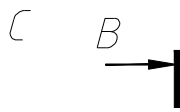

B-B

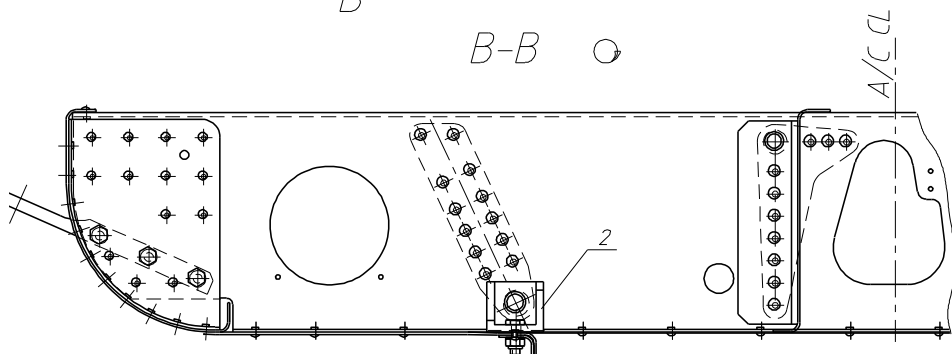

Fig. 2