

AEROPRAKT

INFORMATION BULLETIN

REPLACEMENT OF THE DOOR AIR SCOOPS OF A-22 AIRCRAFT

IB A-22-07

MANDATORY

Repeating symbols:

Please, pay attention to the following symbols throughout this document marking important information.

- ▲ **WARNING:** Identifies an instruction, which if not followed may cause serious injury or even death.
- **CAUTION:** Denotes an instruction, which if not followed, may cause severe damage.
- ◆ **NOTE:** Information useful for better handling.

1) **Planning information**

1.1) **Aircraft affected**

All versions of Aeroprakt-22 aircraft from №1 to №263, which had problems with door air scoops.

1.2) **Reason**

The air scoop has the shape of a lens which focuses the direct sun light and causes melting of the seat cushions and floor rugs.

1.3) **Subject**

Door air scoops

1.4) **Approval**

The technical content of this Information Bulletin has been approved by Aeroprakt.

1.5) **Manpower**

Estimated man-hours:
None

1.6) **Mass data**

None

1.7) **Other publications affected**

None

1.8) **Spare parts**

Spare parts are supplied upon request of aircraft owner.

2) Replacement part information

2.1) Replacement part – cost and availability

The new air scoops are supplied free of charge, excluding delivery.

2.2) Special tooling / materials

None

3) Accomplishment / Instructions

3.1) Instructions

- 1) Remove the old air scoop.
- 2) Squeeze the new air scoop (2) by hand and install it in the place of the old one.
- 3) Install the scoop handle (3).

◆ **NOTE:** The air scoop must be installed from outside and the scoop handle – from inside.

▲ **WARNING:** In cloudless weather the sun rays, passing through the air scoop, can melt the material of the seat cushions and floor rugs. In the new air scoops this effect is excluded due to the uniform glass thickness over the surface of the air scoop.

4) Appendix

The following drawings contain additional information

Fig. 1

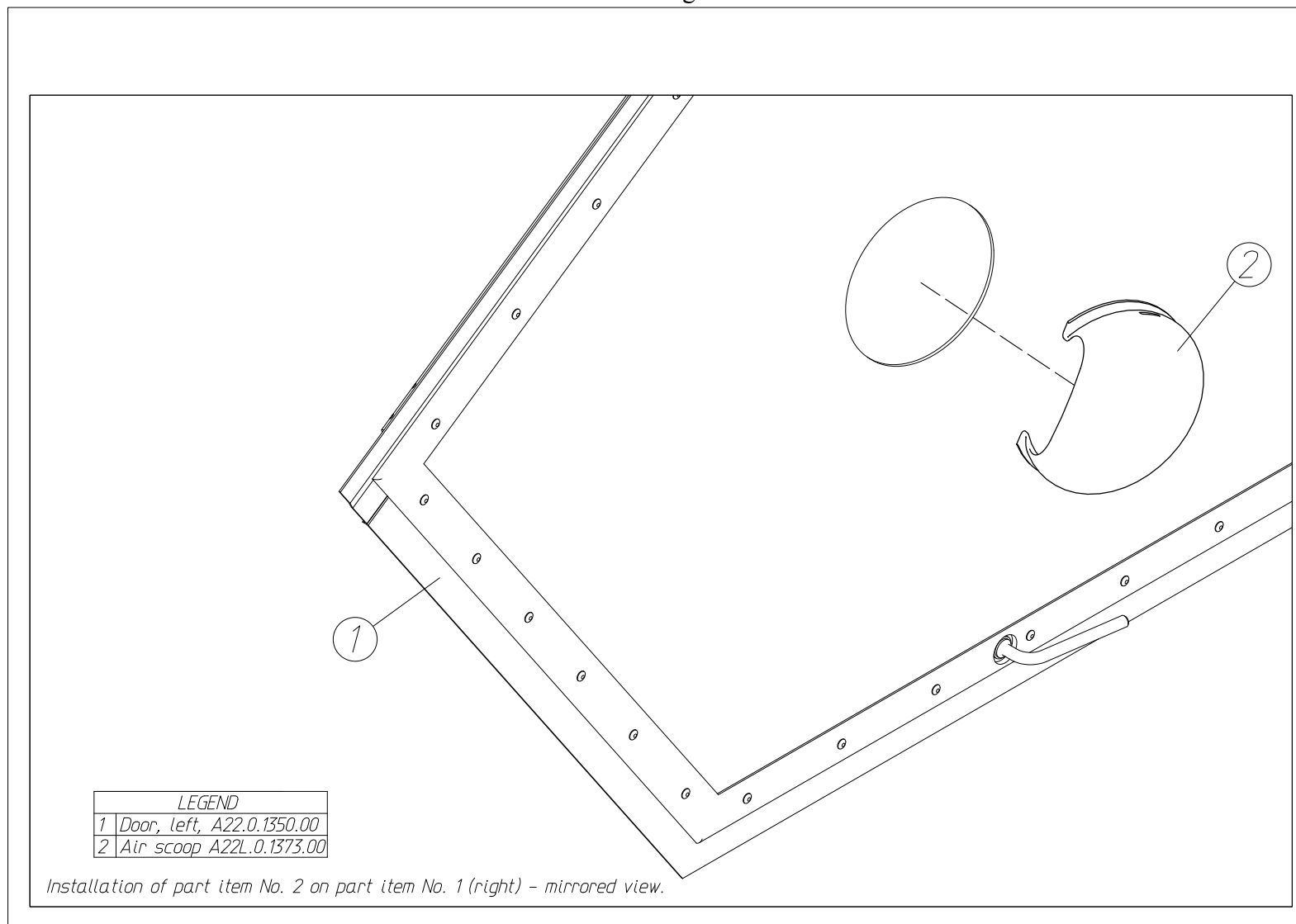

Fig. 2

